

Service Manual
Buttonhole machine

ZOJE

ZJ781-BD

Table of Contents

1. The height of the needle bar
2. The cooperation of the needle and the hook
3. Matching of the baseline adjustment handle
4. The needle bar cooperation
5. The adjustment of the needle drop
6. The height of the needle bar swing fork
7. The position of the under feeding crank
8. Front and rear position of the presser foot
9. Cutter falling time
10. The position of the cutter falls
11. Knife of action hook position
12. Adjustment of the stop device
13. Start the position of the security hook
14. The amount of back and forth movement of the upper knife
15. Left and right position of the upper knife
16. Height of the upper scissors
17. The position of the roll into the upper thread at the start of sewing
18. The time when the scissors are opened
19. Adjustment of the limit plate
20. Safety crank adjustment
21. Upper scissors spring pressure
22. Fixed knife position
23. Height of the presser plate
24. Low speed bump position
25. Starting lever and starting ram position
26. Belt adjustment

The adjustment of other parts

1. Adjust the position of the left and right stitches according to the width of the hole:
2. Adjustment of the tension opening time
3. Adjustment of the wiper
4. Adjustment of thread adjustment hook
5. Lower thread lever adjustment
6. Lower thread tension spring
7. Adjustment of the bobbin pressure bar device

1. The height of the needle bar:

Adjustment requirements:

When the needle bar is at the lowest point, the distance between the lower end surface of the needle bar and the upper plane of the needle plate is 11.9 mm.

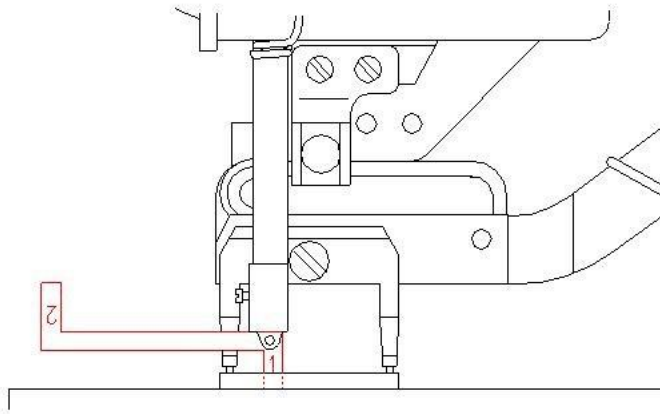

Adjustment method:

(1) Insert the positioning ruler between the needle bar and the needle plate, loosen the needle bar, and tighten the screws to adjust.

Note: the needle should fall in the center of the needle plate.

The phenomenon when the adjustment value changes:

When sewing elastic fabric, the needle bar is lowered a little more than the standard value, and the effect is better.

2. The cooperation of the needle and the hook:

Adjustment requirements:

When the needle bar is lifted by 2.3mm from the lowest point, the center of the hook tip and the needle should be the same, and the upper end of the needle eye is 1.6~1.8mm; the lateral gap between the needle and the hook tip is about 0.05mm.

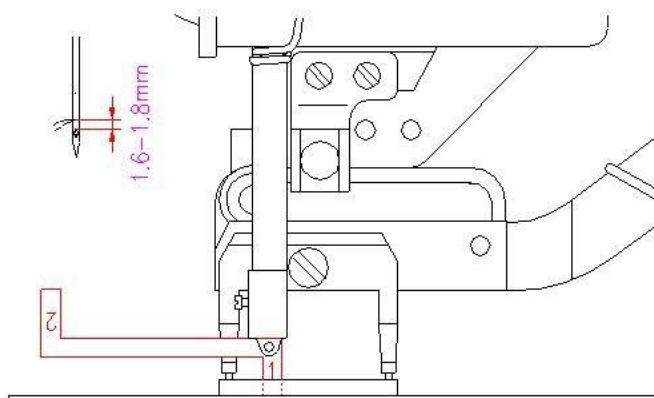

Adjustment method:

- (1) With the needle bar rising from the lowest point, place the positioning scale 2 between the needle bar and the needle plate, and then loosen the set screw of the hook sleeve to adjust.
- (2) At this time, adjust the lateral clearance of the needle and the hook tip to about 0.05 mm, and swing it to the left and right to check and not touch.
- (3) At this time, adjust the gap between the hook positioning hook and the hook to 0.5mm, and loosen the screw of the hook positioning hook to adjust. (Keep the line pass smoothly)

The phenomenon when the adjustment value changes:

- (1) When sewing elastic fabric, slow down the cooperation time of the hook to the needle, and the effect is better. (The distance between the tip of the hook and the upper end of the needle eye is about 1.0mm)

3. Matching of the baseline adjustment handle (adjusting the parallel gap between the cutter and the left and right amplitudes)

Adjustment requirements:

- (1) Position of the parallel portion on the left side: The lower end of the left baseline adjustment screw is 10 mm from the upper plane of the baseline adjustment handle, and the lower plane of the baseline adjustment handle is exposed to be about 1 mm.
- (2) Position of the right parallel portion: The adjustment of the right baseline should be adjusted to the A=B position according to the amplitude of the parallel portion.

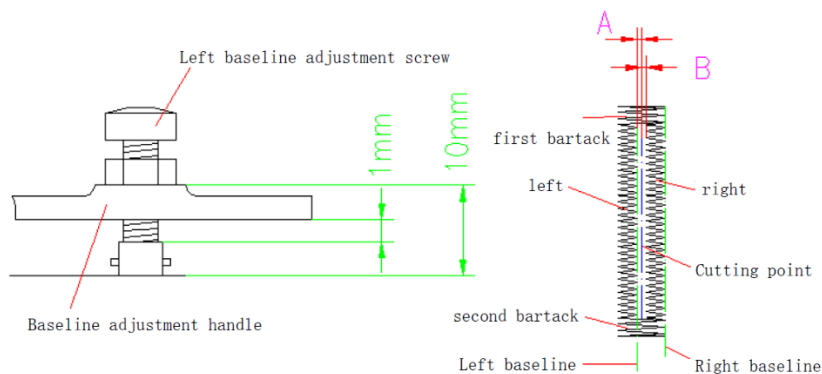

Adjustment method:

- (1) Adjustment of the left baseline should be performed when the needle falls in the center of the needle plate hole. The distance between the lower end of the left baseline adjustment screw and the plane above the baseline adjustment handle is approximately 10 mm, which is adjusted by the left baseline adjustment screw (see figure).
- (2) The adjustment of the right baseline is performed with the right baseline adjustment screw.

(3) Adjust the left and right baselines so that the cutter falls in the center of the parallel portion.

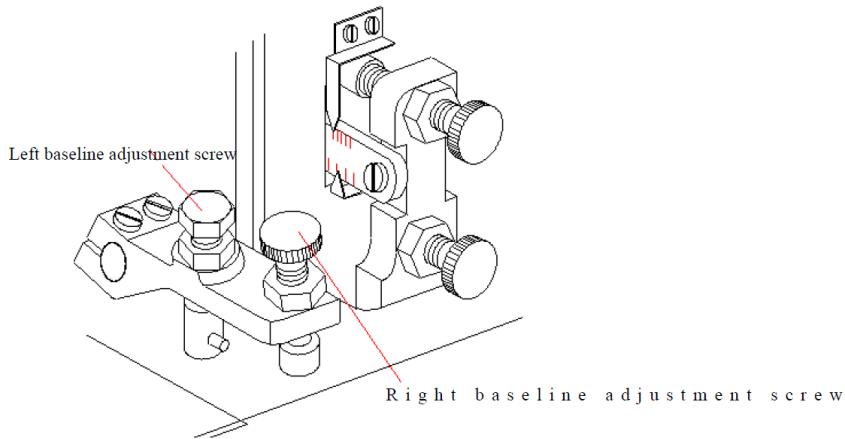

(4) Adjustment order of amplitude and baseline: 1 change of course amplitude 2 Observation of the distance between the inside of the amplitude of the right course and the falling point of the cutter 3 Adjusting the position of the right baseline 4 Adjusting the amplitude of the reinforcement

The phenomenon when the adjustment value changes:

When adjusting the left and right baselines, it is biased toward either side, and the stitches adjacent to the parallel portion of the cutter may be biased to the inner side.

When the amplitude is increased, the left parallel portion is individually biased to the left.

4. The needle bar cooperation:

Adjustment requirements:

(1) When the needle is at the top center, the engraved line of the pinion gear should be aligned with the center of the lower shaft.

(2) If there is no engraving on the pinion gear, when the needle bar is at the lowest point, the center of the oil hole on the convex arc of the large arc of the needle pendulum (ie the center of the convex arc of the cam) is aligned with the needle bar. Swing the left side of the plane (viewed from the front).

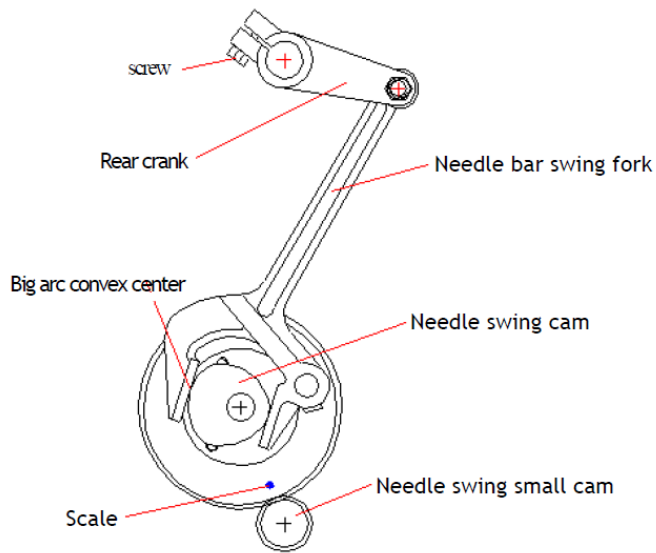

Adjustment method:

Loosen the fixing screw of the pinion gear to adjust the above standard adjustment value. Pay attention to the axial movement of the lower shaft when adjusting. Confirmation method after adjustment: pad the paper at the needle drop and turn the pulley by hand to observe whether there is a lateral flow needle phenomenon on the needle drop point on the paper, that is, to ensure that the swing of the needle before the needle bar is lowered to the front of the puncturing cloth should end.

The phenomenon when the adjustment value changes:

When the reticle is missed, it will cause the needle to flow, the needle to break, and the needle to jump.

5. The adjustment of the needle drop (for the needle board)

Adjustment requirements:

When sewing the parallel portion on the left side, the swing fork is at the leftmost end when the needle is lowered to the middle portion of the needle plate hole.

Adjustment method:

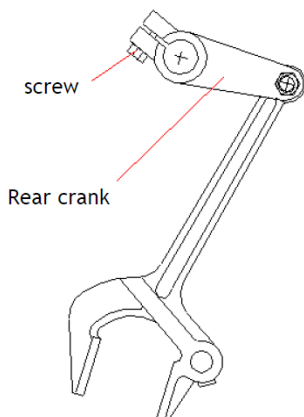

When the position of the needle bar swing fork is normal, and the needle drop point is not correct, the tightening screw of the crank shaft after the swing shaft can be loosened to be corrected.

The phenomenon when the adjustment value changes:

If the needle drop point is wrong, it will increase the needle swing amplitude, and the inaccurate one will hit the needle plate hole and cause the needle break or thread break.

6. The height of the needle bar swing fork

Adjustment requirements:

When the machine is in the parking position (the needle is in the left needle position), the distance from the large arc of the needle cam to the top of the needle bar swing fork is about 5 mm.

Adjustment method:

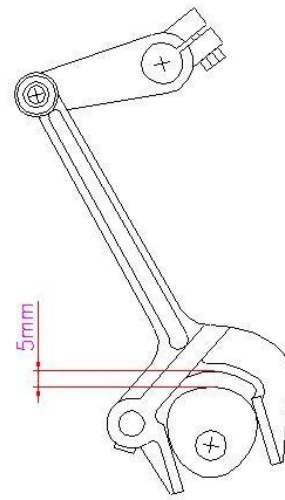
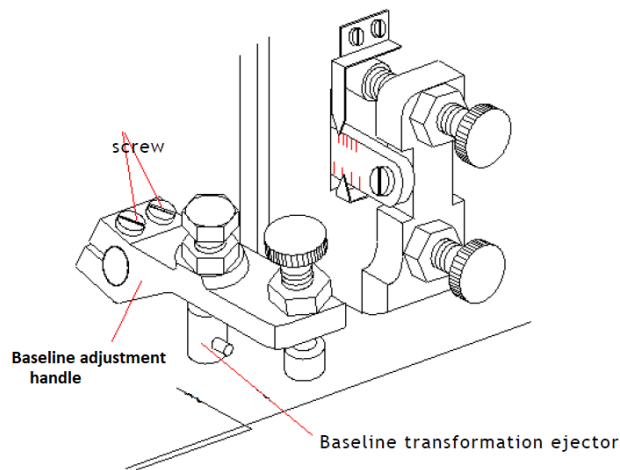

When the machine is in the parking position (the needle is in the left needle position), loosen the fastening screw on the baseline adjustment handle, push down the needle bar swing fork, so that the large arc of the needle swing cam is convex to the top of the needle bar swing fork. About 5mm, adjust the shank to the baseline adjustment shank, and then tighten the baseline adjustment shank.

Note: When making this adjustment, please remove the spring of this mechanism and adjust it. Check if the needle-swing cam of the needle-spindle gear rotates smoothly.

The phenomenon when the adjustment value changes:

If the height of the needle bar swing fork is not accurate, the width of the left and right courses will be different.

7. The position of the under feeding crank

Adjustment requirements:

Even if the sewing size (adjustment button hole length) is changed, the position of the presser foot does not change during parking, and the position of the feed carriage does not change.

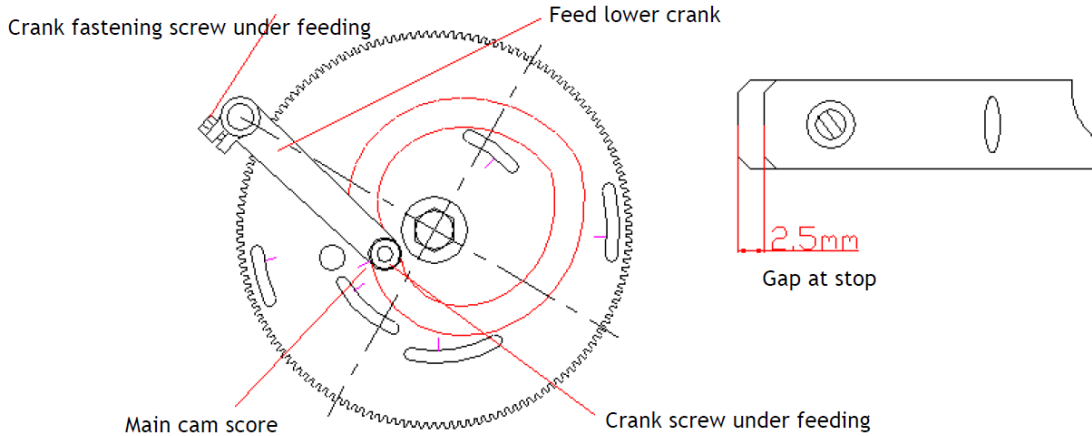

Adjustment method:

Rotate the main cam with the manual feed handle. When the main cam engraving line is aligned with the center of the roller pin screw of the feeding lower crank, loosen the fastening screw of the lower crank and then loosen the button hole length nut. When the plate moves to a distance of 2.5mm from the needle plate (see picture), move the button hole length adjustment screw in the arc groove of the feed crank body. If the presser foot does not move back and forth, the position of the crank under the feed is correct. When the crank body does not move, tighten the fastening screw of the lower crank.

The phenomenon when the adjustment value changes:

If the position is wrong, whenever the sewing size is changed, the action of the scissors will fail, and the position of the presser foot will also change, causing a broken needle or thread broken.

8. Front and rear position of the presser foot

Adjustment requirements:

The gap between the center of the needle drop hole and the inner end surface of the presser foot is 2.5 mm (when the vehicle is parked), and the presser foot plate is located at the same position on both sides of the needle blade slot.

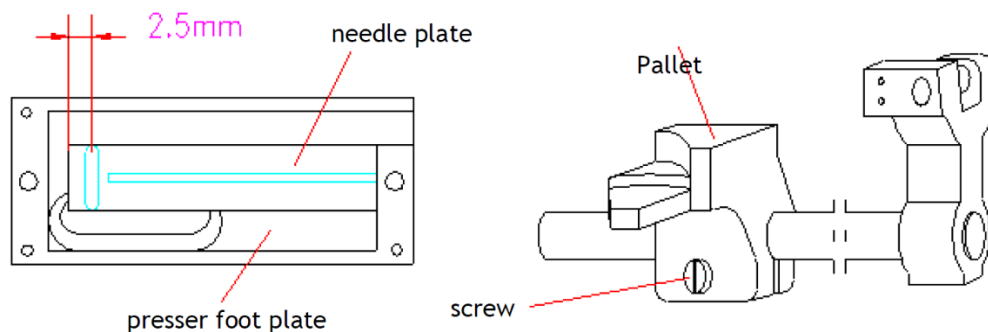

Adjustment method:

When the machine is in the parking position, loosen the fastening screws of the pallet to adjust.

Confirmation after adjustment: Please confirm that the lifting arm is perpendicular to the bottom plate.

The phenomenon when the adjustment value changes:

(1) If the position of the presser foot is not accurate, the front and rear positions of the presser foot are not accurate, and the opening and closing action of the upper scissors action plate is affected.

(2) When the parking is stopped, the gap between the center of the needle hole and the presser foot is too small. When the sewing machine is in contact with the presser foot during sewing, the thread is broken and the needle is broken.

9. Cutter falling time

Adjustment requirements:

After the sewing machine is completely decelerated, it will fall 2~3 before the stop (1 2 3 pin is the reference).

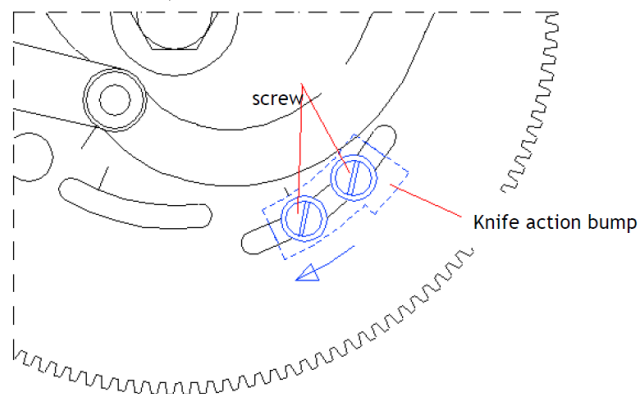

Adjustment method:

Move the cutter action bump position and adjust the cutter fall time to 2~3 stitches before the sewing machine stops.

Moving in the direction of the mark, the cutter falls early.

Note: When the number of stitches is adjusted to 93 or less, adjust the low speed bumps.

The phenomenon when the adjustment value changes:

When the cutter is operated during high-speed operation, the cutter will not fall, and the cutter will be accelerated.

10. The position of the cutter falls

Adjustment requirements:

Should fall in the middle of the needle plate slot.

Adjustment method:

Loosen the needle plate seat fastening screw and move the needle plate seat position to adjust.

The phenomenon when the adjustment value changes:

When the position is wrong, the cutter hits the needle plate.

11. Knife of action hook position

Adjustment requirements:

The clearance between the cutter drive lever and the knife of action hook at the lowest point is 0.05~0.2mm.

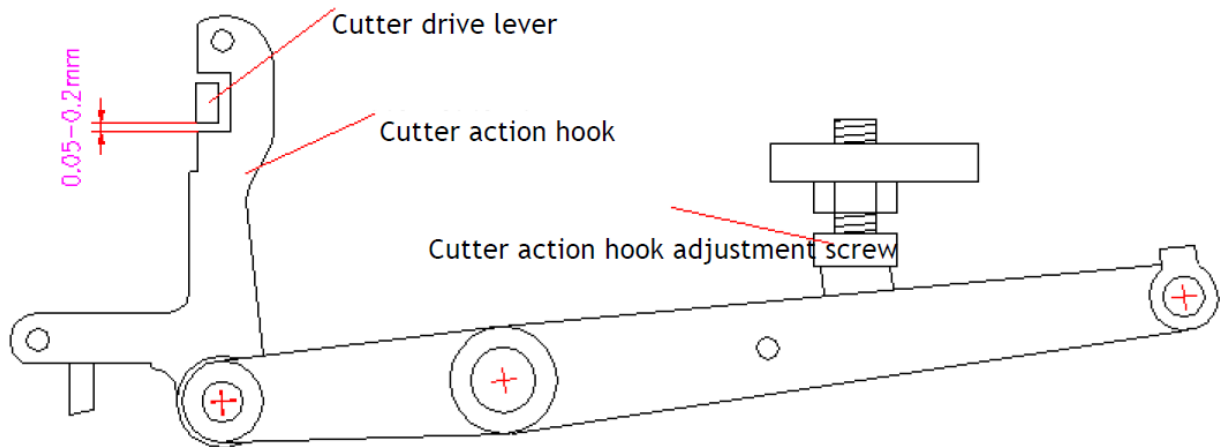

Adjustment method:

Use the knife of the drive hook adjustment screw to adjust.

The phenomenon when the adjustment value changes:

- (1) When the cutter does not return or continuously falls, check the gap between the cutter drive lever and the cutter action hook, or change the cutter drive lever tension spring.
- (2) The cutter often does not fall down, and it is not possible to drop the knife at a low speed. It may be that the tension spring of the cutter driving claw is insufficient. (replace the tension spring)

12. Adjustment of the stop device

Adjustment requirements:

The clearance between the stop sub-block A and the stop lever block B is 0.2 to 0.5 mm (when parked).

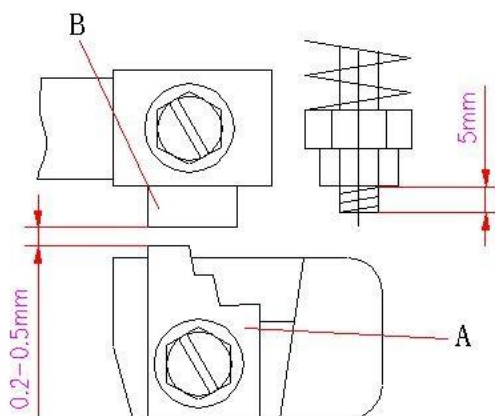

Adjustment method:

- (1) Move the stop block A up and down to adjust.
- (2) Adjustment of the stop buffer rod spring: When the hex nut is adjusted to the stop buffer rod to expose 5mm, tighten it.

Adjusted confirmation method:

The stop frame is adjusted to a high speed running state, and the manual stop handle is rotated, the stop block must release a first gear, enter a low speed state, and then release the second gear to enter a stop state.

The phenomenon when the adjustment value changes:

- (1) At the parking position, the clearance between the stop sub-block A and the stop lever block B is too small, and there is no stopping.
- (2) When the hex nut loosens and the sewing machine stops, the height of the needle changes.

13. Start the position of the security hook

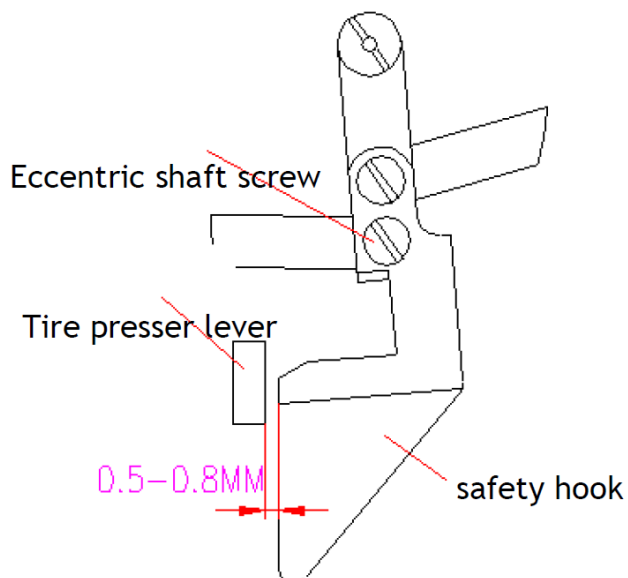

Adjustment requirements:

When parking, the distance between the start safety hook and the lifter lever is 0.5~0.8mm.

Adjustment method:

Adjust with the rotating eccentric shaft screw.

The phenomenon when the adjustment value changes:

If there is no gap, it will be in a state of conflict, causing the presser foot not to return. On the contrary, if the gap is too large, it will not stop.

14. The amount of back and forth movement of the upper knife

Adjustment requirements:

The amount of back and forth movement is 4~5mm.

Adjustment method:

(1) Loosen the roller shaft fixing screw in front of the presser foot connecting rod, adjust the amount of back and forth movement of the upper knife, move to the right to increase the amount of movement, and shift to the left to decrease.

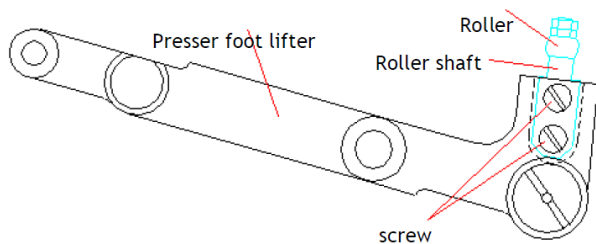

(2) Note: The adjustment of this part is a slight adjustment, please do not adjust excessively

The phenomenon when the adjustment value changes:

When the amount of front and rear movement is excessively adjusted, the protruding portion of the scissor swing frame will slide out from the groove of the presser roller frame. Once it is slipped out, the presser foot cannot be lifted and the feeding becomes heavy.

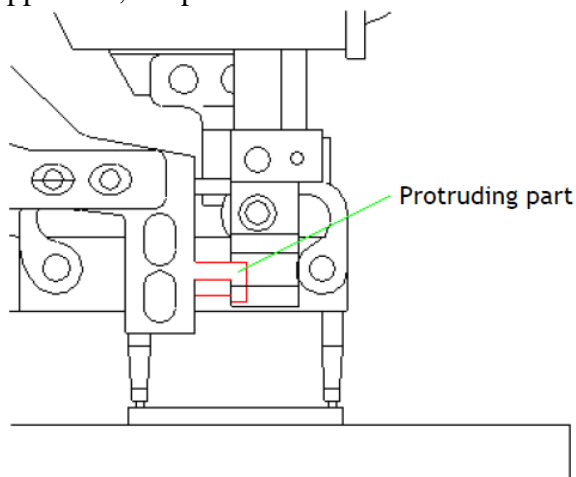

15. Left and right position of the upper knife

Adjustment requirements:

(1) The upper scissors is aligned with the center of the needle when it advances to the foremost end; and the front end of the scissors protrudes 5 mm to the right from the center of the cutter groove.

(2) When the upper scissors is closed, the overlap between the upper knife and the lower knife is 0.5~0.8mm. Please note that there is still a gap even if it is closed.

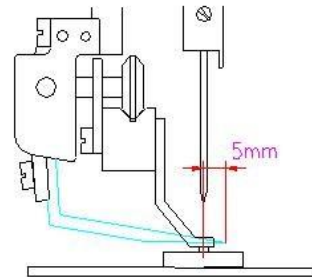
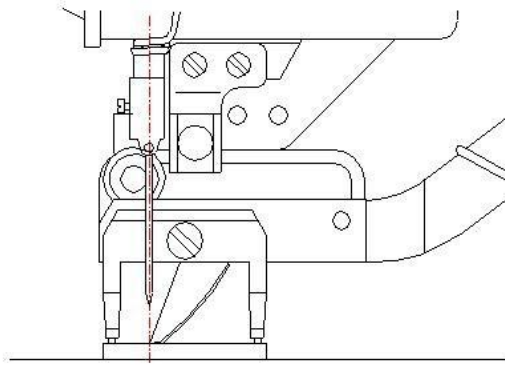

Adjustment method:

(1) Step on the presser foot pedal. When the upper thread scissors move to the apex, use a hex wrench to loosen the fixing screws of the scissors pendulum and adjust the position of the front, back, left and right.

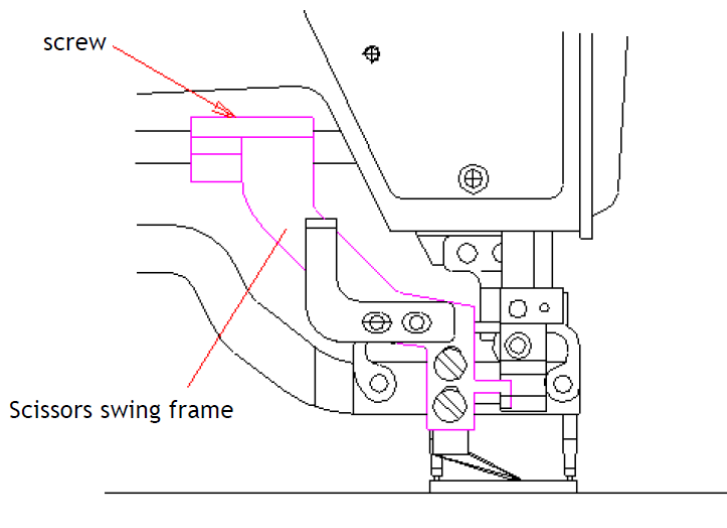

(2) Loosen the fixing screw of the upper scissors action plate A and adjust the amount of overlap between the upper knife and the lower knife.

The phenomenon when the adjustment value changes:

- (1) When the front, back, and left and right positions are not good, when the presser foot is raised, the scissors swing frame is caught and cannot move smoothly.
- (2) The position of the scissors action board A is too far forward to produce the upper line cut continuously. (scissors are not close together)
- (3) When the position of the scissors action board A is too backward, the scissors will be closed when the line is not clamped.

16. Height of the upper scissors

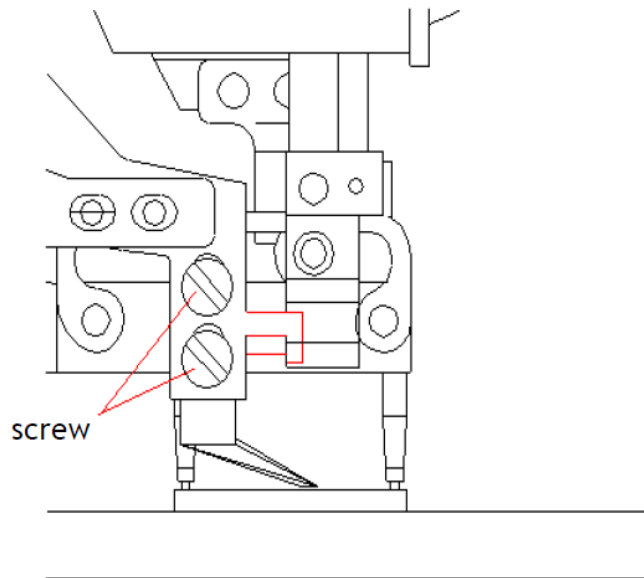

Adjustment requirements:

Install the scissors as low as possible, but do not touch the presser foot.

Adjustment method:

Loosen the fixing screws of the upper scissors and adjust them up and down. Confirmation method after adjustment: Place a gasket with a thickness of about 4 mm under the presser foot. When moving the presser foot lever up and down, the presser foot and the scissors should not touch each other.

The phenomenon when the adjustment value changes:

The position of the scissors is too high, and sometimes the thread will remain on the knot.

17. The position of the roll into the upper thread at the start of sewing

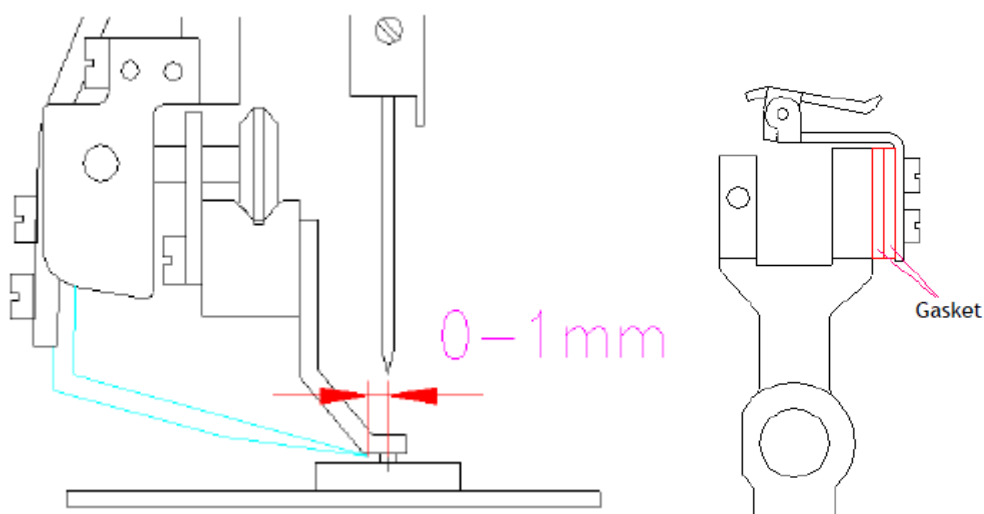

Adjustment requirements:

At the beginning of the sewing, the top end of the upper scissors leaves the center of the needle cutter slot 0 to 1 mm to the left.

Adjustment method:

This position is adjusted by increasing or decreasing the number of wire head control pad spacers.

Note: There is also a relationship with the position where the upper scissors clamps the wire, so confirm the position of the upper scissors action plate, and then increase or decrease the wire control plate gasket.

The phenomenon when the adjustment value changes:

The upper scissors is too far to the right and the upper line will be beyond the right side of the stitch. On the contrary, the upper line will be beyond the left side of the stitch.

18. The time when the scissors are opened

Adjustment requirements:

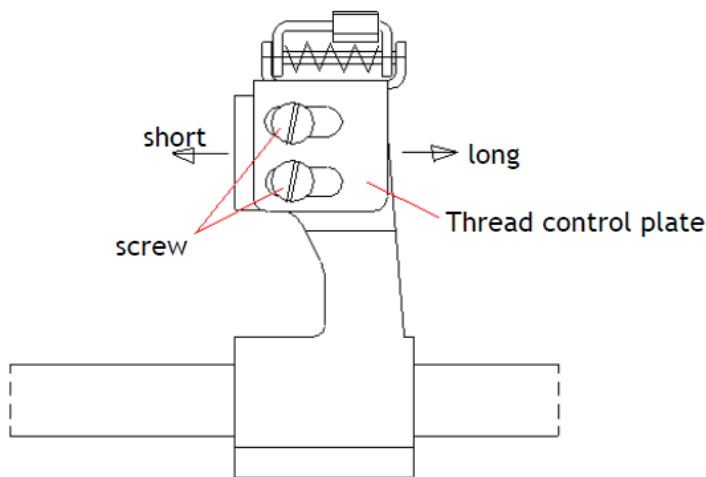

Adjustment method:

(1) Loosen the wire head control plate fixing screw and move the control board back and forth to adjust.

(2) The time to move the control board forward to clamp the upper line is longer, and on the contrary, it is shortened.

Confirmation method after adjustment:

After adjustment, turn the manual feed handle, you must check that the scissors do not touch the presser foot and needle when opening.

The phenomenon when the adjustment value changes:

(1) When the upper scissors is opened quickly, it may cause sewing not good and off-line when the needle is lifted.

(2) When the upper scissors are opened slowly, the stitching is not good at the beginning of the sewing.

19. Adjustment of the limit plate

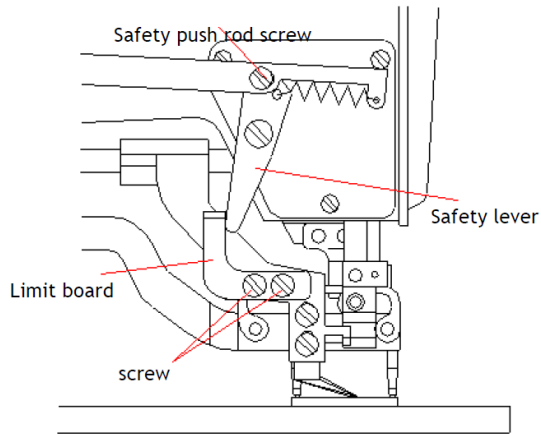

Adjustment method:

Loosen the limit plate fixing screw so that the sewing machine is in a state of low speed start (when the stop block A and the stop lever block B meet) the safety lever is in light contact with the limit plate.

Adjusted confirmation method:

- (1) When the safety lever is pressed toward the mark in the high-speed start state, there should be no gap in the long hole at the safety pusher shaft screw.
- (2) There should be a gap between the safety lever and the limit plate when parking and upper scissors moving.

The phenomenon when the adjustment value changes:

Note: After an emergency stop, the presser foot should be raised at the needle up position.

20. Safety crank adjustment

Adjustment method:

After the upper scissors shaft is pulled away from the thread control board, the overlap between the safety crank and the safety bump is 0.5 mm when the scissors are opened.

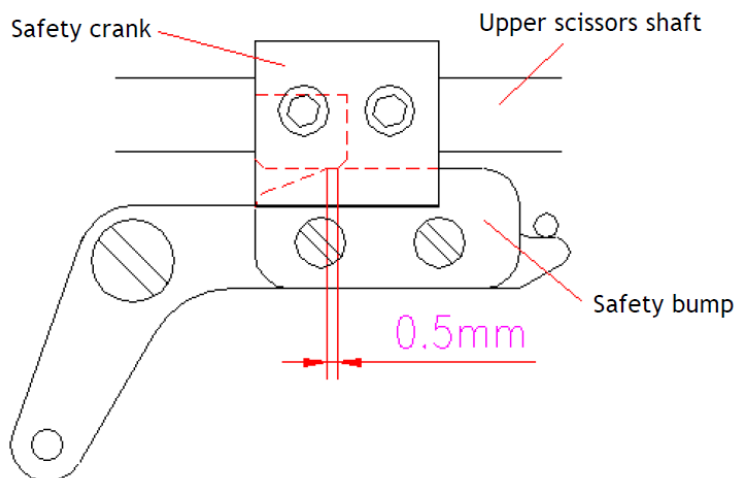

The phenomenon when the adjustment value changes

If it does not engage, the opening action of the scissors is not good.

21. Upper scissors spring pressure

Adjustment method:

(1) When the upper thread scissors are loose, move the front of the scissors spring with the hand plate. The front of the upper scissors spring and the scissors mouth are all attached, and the thread can be clamped regardless of where the scissors cut the thread.

(2) When the upper scissors edge is not sharp, the scissors can be replaced.

22. Fixed knife position

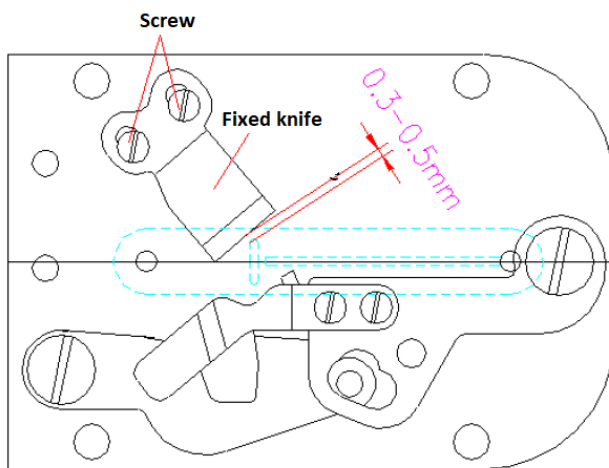

Adjustment requirements:

The fixed knife edge is 0.3~0.5mm away from the needle plate hole.

Adjustment method:

- (1) Loosen the fixed knife fixing screw for the fixed knife adjustment.
- (2) When changing the fixed knife, take out the hook finger to replace it.

The phenomenon when the adjustment value changes:

The gap between the fixed knife and the hole of the needle plate is too narrow, and it is easy to break when sewing.

23. Height of the presser plate

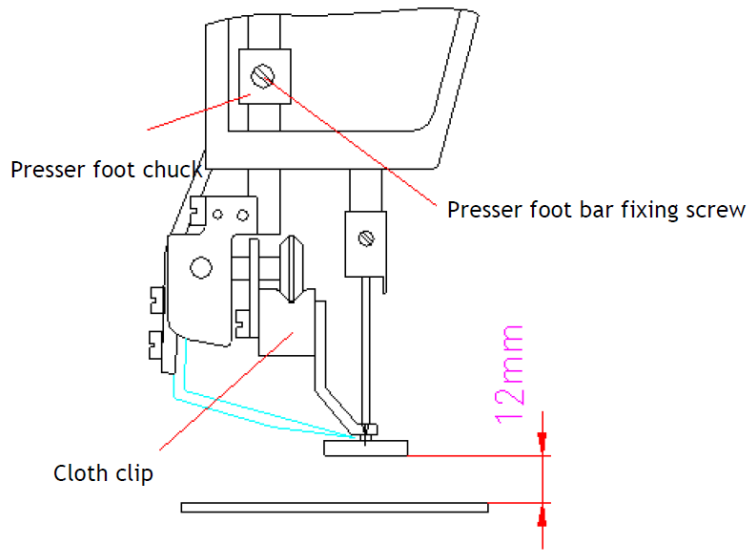

Adjustment requirements:

The lifting amount of the presser foot is 12mm

Adjustment method:

Insert the 12mm pad between the presser foot and the needle plate, loosen the presser foot fixing screw, press the presser foot lifting pedal, and press the presser foot clamp and the presser foot roller frame, then tighten the presser foot fixing screw .

Confirmation after adjustment: After adjustment, it must be confirmed that the presser foot can work normally.

24. Low speed bump position

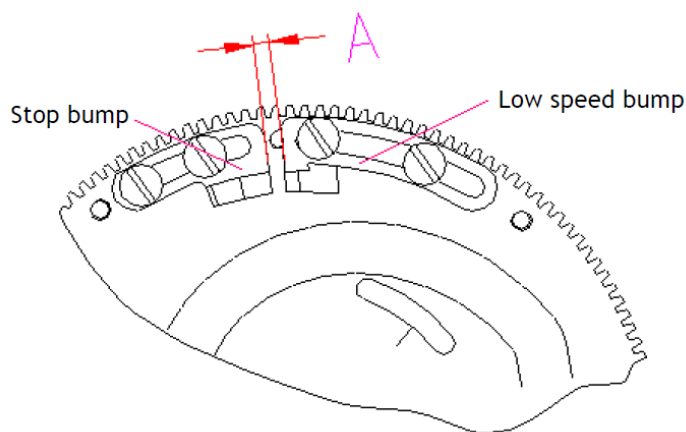

Adjustment method:

Adjust the size of A according to the number of stitches used to loosen the fixing screws of the low-speed bumps.

stitches	A size
----------	--------

under 93 stitches	10~12mm
between 93-123	5mm
More than 123 stitches	0

The phenomenon when the adjustment value changes:

Moving the low-speed bumps counterclockwise can reduce the number of stitches from low speed to stop.

25. Starting lever and starting ram position

Adjustment method:

When the machine is stopped, the gap between the end of the adjusting screw on the starting ram and the stop frame is 0.5~1mm; the gap between the starting lever and the convex surface of the fuselage base is 3mm.

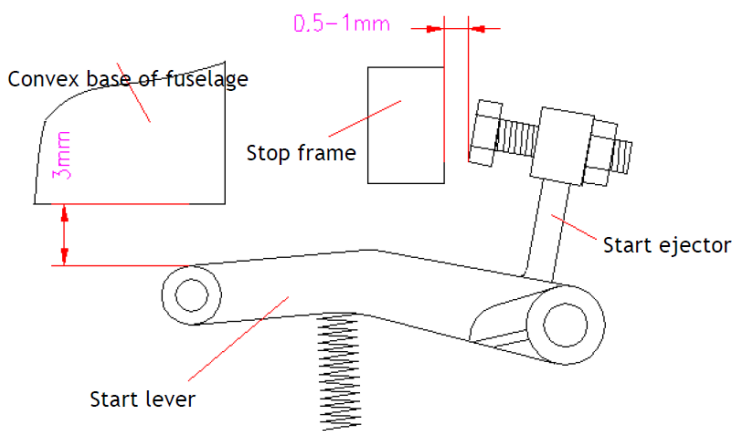

The phenomenon when the adjustment value changes:

If the gap at the starting ram is too large, it cannot be rotated at a high speed. If it is small, it will cause an inaccurate stop.

26. Belt adjustment

Head start fork position:

Adjustment method:

When idling, the belt is exposed from the runner by about 0.5~1mm, which is adjusted by the long hole of the starting fork (on the nose). At low speed, the belt should completely cover the drive pulley.

Note: When idling, try not to make the belt contact the starter fork (on the handpiece).

The phenomenon when the adjustment value changes:

When idling, if the belt is wrapped around the drive pulley, the belt will be easily worn and the pulley will heat up.

Speeding mechanism fork position

Adjustment method:

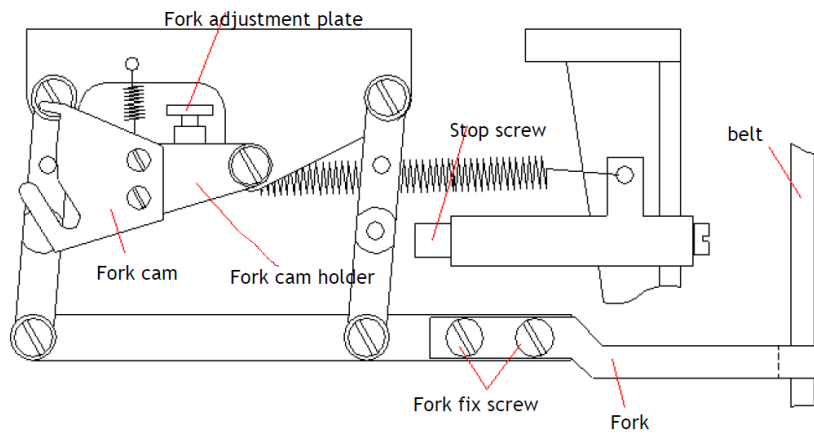

Same as the adjustment method of the head start fork. When the low speed is running, loosen the fixing screw of the speed reduction mechanism fork and adjust the position of the speed reduction mechanism fork. However, adjust the limit screw at high speed.

The standard movement of the fork is 14mm. Adjust the pad with the shift fork to adjust. When you spin it out, the stroke is reduced.

Note: If the fork is swung too far at low speed and parking, the fork cam is not properly installed. Therefore, the fork cam should be installed parallel to the processing surface of the fork cam holder.

The phenomenon when the adjustment value changes:

When the speed adjustment mechanism fork adjustment is not possible, please adjust the fork adjustment pad.

The adjustment of other parts

1. Adjust the position of the left and right stitches according to the width of the hole:

(1) Swing of the needle: based on the right side, Sew the needle to the left side for sewing. In the figure, A is the left baseline, B is the right baseline, W1 is the left and right horizontal amplitude width, W2 is the reinforcement amplitude width, C is the first reinforcement length (first set), and D is the second reinforcement length (second set) .

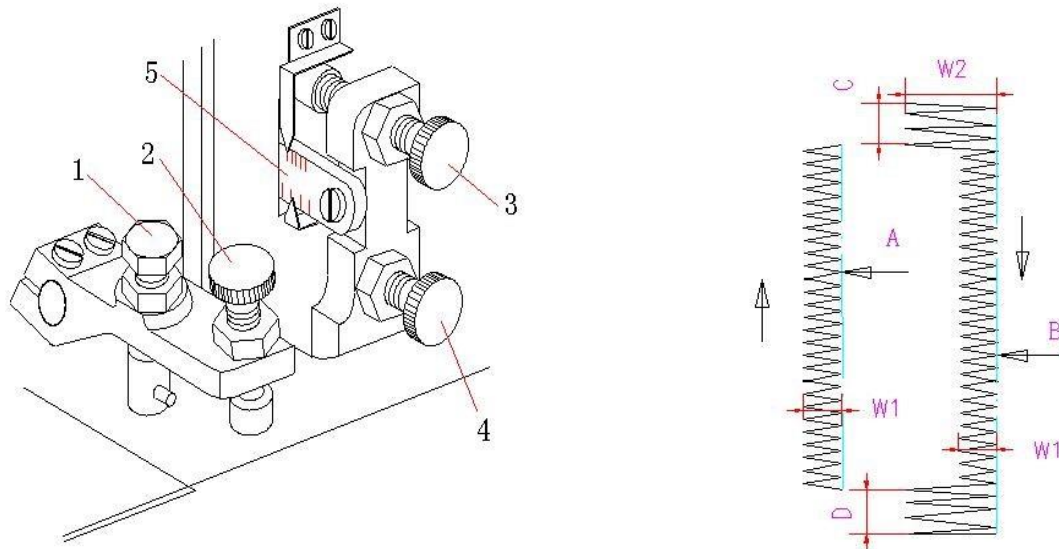

(2) Adjustment of left baseline and right baseline

1 Rotate the adjusting screw 1, and the left baseline moves to the left; when the adjusting screw 1 is unscrewed, the left baseline moves to the right, but even if the amplitude is changed, the left baseline A hardly needs to be adjusted. 2 Screw in the screw 2, the right baseline will move to the left, and when it is rotated, it will move to the right.

Adjustment of horizontal width and reinforcement width

1 Rotate the adjustment screw 3, the width of the course will increase, and the rotation will decrease.

2 Screw in the adjusting screw 4, the reinforcement width will increase, and the screw-out will decrease.

3 The amplitude adjustment link 5, the number shown, indicates the width of the reinforcement amplitude.

2. Adjustment of the tension opening time

First tension

The first tension is opened only when the machine is stopped, and the opening amount is 0.5~1mm, and the height of the first tension is moved up and down to adjust.

Second tension

The second tensioner is opened in the reinforcement part of the serrated seam and a few needles after the sewing is completed, and the opening amount is 0.5~1 mm. When adjusting, loosen the set screw and adjust the position of the gripper to adjust.

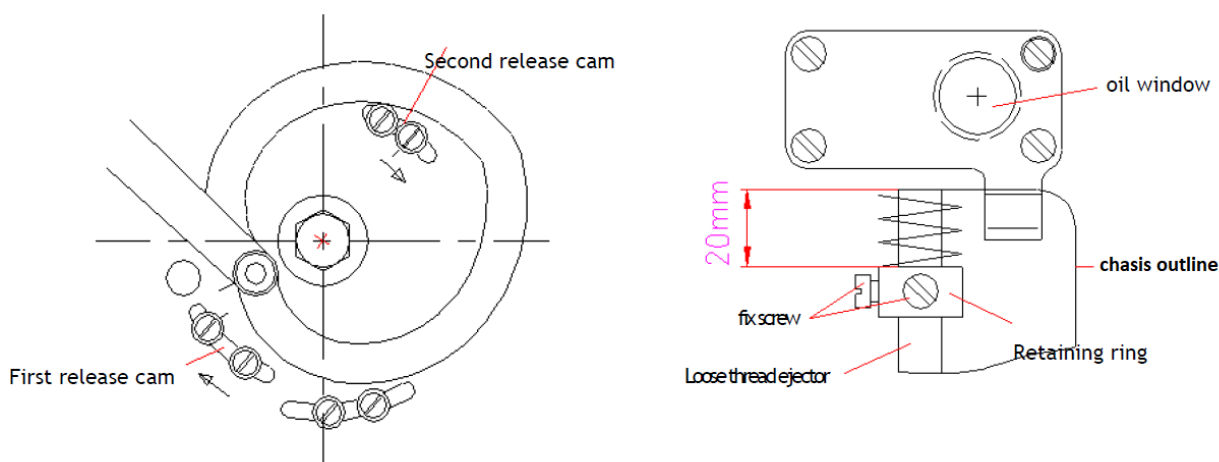

The first loose wire bump and the second loose wire bump on the main cam are rotated in the direction of the arrow to speed up. The opposite is slow.

3. Adjustment of the wiper

When the machine stops, the threaded wiper will loosen the upper thread by 5~7mm, which can prevent the off-line phenomenon when starting the seam. When the thread is removed, the amount of the thread will increase. When adjusting, do not touch the first tension and through the hole.

4. Adjustment of thread adjustment hook

The amount of thread supply is adjusted according to the thickness of the sewn product, so that the stitches to be sewn will become better, the amount of thread adjustment hooks will increase to the left, and the amount of movement to the right will decrease.

5. Lower thread lever adjustment

Adjust the length of the lower thread required to start sewing. The length of the lower thread is about 36mm. When adjusting, loosen the fixing screw of the lower thread lever to change the installation angle of the lower thread lever.

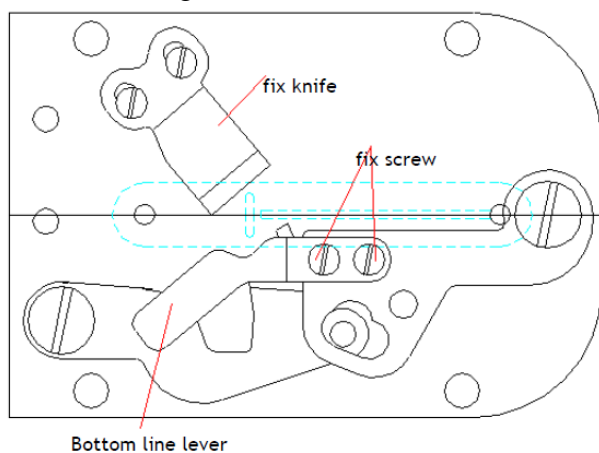

(Action sequence): Upper thread scissors action → Lower thread lever action → Lower line moving knife action

<Upline scissors action>----- Cut section thread

<Lower thread lever action>-----Pull out the lower thread required for the initial seam and pull in the remaining upper thread

< Lower line moving knife action>----- cut the lower line while the presser foot starts to rise

6. Lower thread tension spring

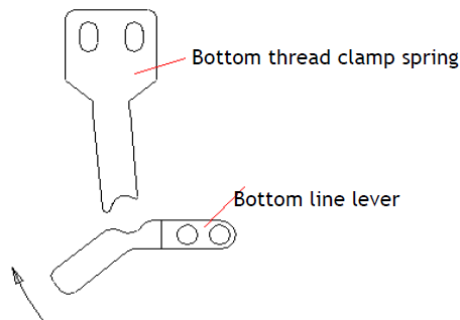

Loosen its fixing screw to adjust its installation position so that the “R” part of the lower thread lever is at the center of the clip spring, and the lower thread clamp spring is pulled to gently press the lower thread.

7. Adjustment of the bobbin pressure bar device

The bobbin presser device is in synchronous connection with the bottom thread trimming device. When the lower thread is plucked, the bobbin pressure bar presses the bobbin on the back to prevent idling, and at the same time, the upper thread remaining on the cloth is pulled down to the cloth, and a certain amount of lower thread is ensured to prevent the needle from jumping at the beginning of the seam. Off the line.

Adjustment method:

- (1) If the lower thread is cut short, the pressure of the bobbin is too strong. At this time, the adjusting screw can be loosened to weaken the pressure of the top spring. On the contrary, the adjustment screw is tightened.
- (2) When changing the hook, check if the bobbin is pressed against the bobbin. If it does not match, loosen the bobbin fixing screw to adjust its height.